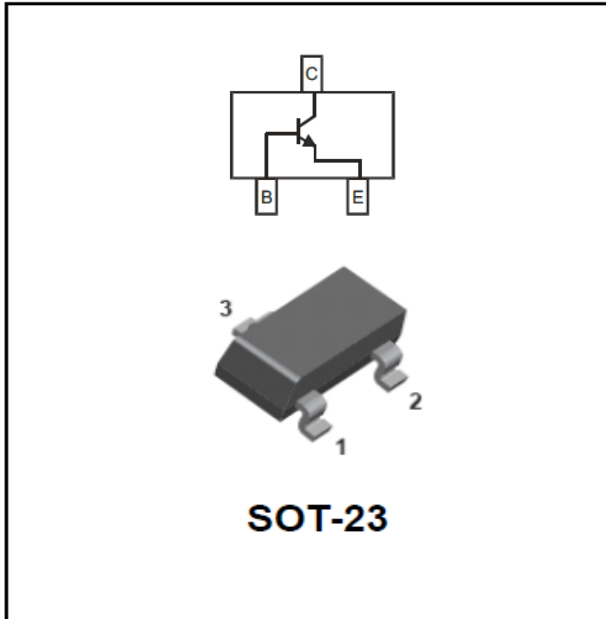

## NPN General Purpose Amplifier

**Features**

- Epoxy meets UL-94 V-0 flammability rating
- Moisure Sensitivity Level 1
- Marking:1AM

**■Off Characteristics**

Item	Symbol	Unit	Conditions	Value
Collector-Emitter Voltage*	$V_{CEO}$	V	$I_C=1.0\text{mA}$ , $I_B=0$	40
Collector-Base Voltage	$V_{CBO}$	V	$I_C=10\mu\text{A}$ , $I_E=0$	60
Emitter-Base Voltage	$V_{EBO}$	V	$I_E=10\mu\text{A}$ , $I_C=0$	6.0
Collector Current	$I_C$	mA		200
Collector Cutoff Current	$I_{CBO}$	nA	$V_{CB}=60\text{Vdc}$	50
Collector Cutoff Current	$I_{CEX}$	nA	$V_{CE}=30\text{Vdc}$	50
Power Dissipation	$P_D$	mW		350
Thermal Resistance Junction to Case	$R_{thJC}$	$^{\circ}\text{C/W}$		185
Thermal Resistance Junction to Ambient	$R_{thJA}$	$^{\circ}\text{C/W}$		357
Operation Junction Temperature	$T_J$	$^{\circ}\text{C}$		-55 to +150
Storage Temperature	$T_{STG}$	$^{\circ}\text{C}$		-55 to +150

\*Pulse Width  $\leq 300\mu\text{s}$ , Duty Cycle  $\leq 2.0\%$

# MMBT3904

## ■ On Characteristics

Item	Symbol	Unit	Conditions	Min	Max
DC Current Gain	$h_{FE}$		$I_C=0.1\text{mA dc}, V_{CE}=1.0\text{V dc}$	40	
			$I_C=1.0\text{mA dc}, V_{CE}=1.0\text{V dc}$	70	
			$I_C=10\text{mA dc}, V_{CE}=1.0\text{V dc}$	100	300
			$I_C=50\text{mA dc}, V_{CE}=1.0\text{V dc}$	60	
			$I_C=100\text{mA dc}, V_{CE}=1.0\text{V dc}$	30	
Collector-Emitter Saturation Voltage	$V_{CE(sat)}$	Vdc	$I_C=10\text{mA dc}, I_B=1.0\text{mA dc}$		0.2
			$I_C=50\text{mA dc}, I_B=5.0\text{mA dc}$		0.3
Base-Emitter Saturation Voltage	$V_{BE(sat)}$	Vdc	$I_C=10\text{mA dc}, I_B=1.0\text{mA dc}$	0.65	0.85
			$I_C=50\text{mA dc}, I_B=5.0\text{mA dc}$		0.95

## ■ Small-signal Characteristics

Item	Symbol	Unit	Conditions	Min	Max
Output Capacitance	$C_{obo}$	pF	$V_{CB}=5.0\text{V dc}, f=1.0\text{MHz}, I_E=0$		4
Input Capacitance	$C_{ibo}$	pF	$V_{EB}=0.5\text{V dc}, f=1.0\text{MHz}, I_C=0$		8
Current Gain-Bandwidth Product	$f_T$	MHz	$I_C=10\text{mA dc}, V_{CE}=20\text{V dc}, f=100\text{MHz}$	300	
Noise Figure	NF	dB	$V_{CE}=5.0\text{V}, f=10\text{Hz to } 15.7\text{kHz}, I_C=100\mu\text{A}, R_S=1.0\text{k}\Omega$		5

## ■ Switching Characteristics

Item	Symbol	Unit	Conditions	Value
Delay Time	$t_d$	ns	$V_{CC}=3.0\text{V dc}, V_{BE}=0.5\text{V dc}, I_C=10\text{mA dc}, I_{B1}=1.0\text{mA dc}$	35
Rise Time	$t_r$	ns		35
Storage Time	$t_s$	ns	$V_{CC}=3.0\text{V dc}, I_{B1}=I_{B2}=1.0\text{mA dc}, I_C=10\text{mA dc}$	200
Fall Time	$t_f$	ns		50

## ■ Ordering Information (Example)

PREFERRED P/N	PACKING CODE	UNIT WEIGHT(g)	MINIMUM PACKAGE(pcs)	INNER BOX QUANTITY(pcs)	OUTER CARTON QUANTITY(pcs)	DELIVERY MODE
MMBT3904	F2	Approximate 0.008	3000	30000	120000	7" reel

# MMBT3904

## ■ Characteristics(Typical)

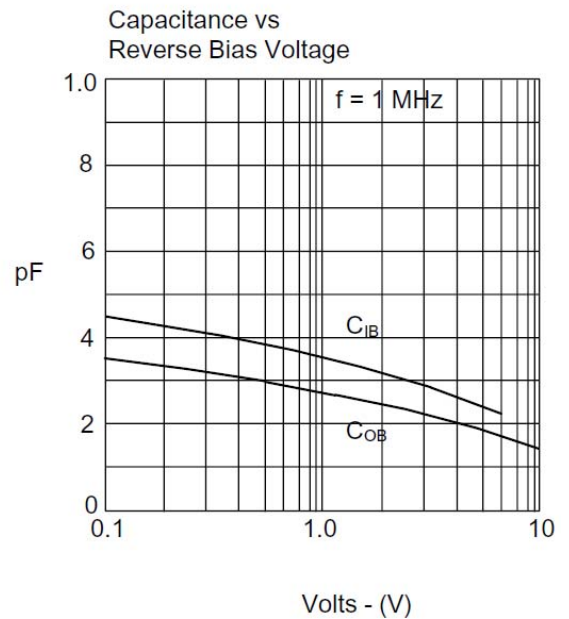
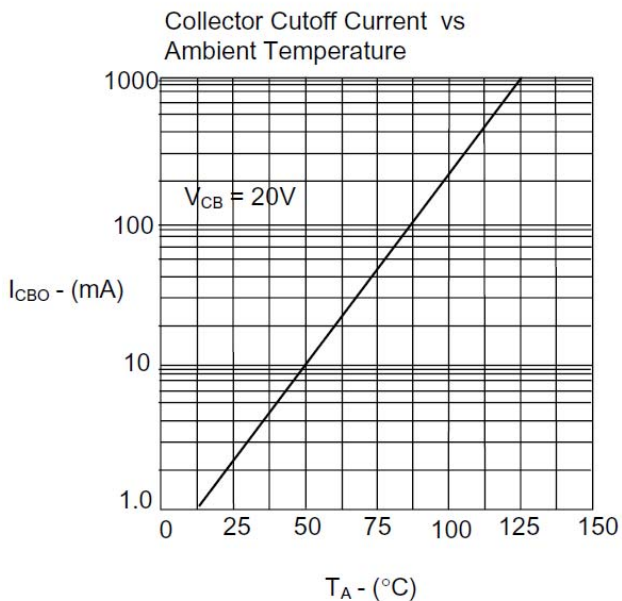
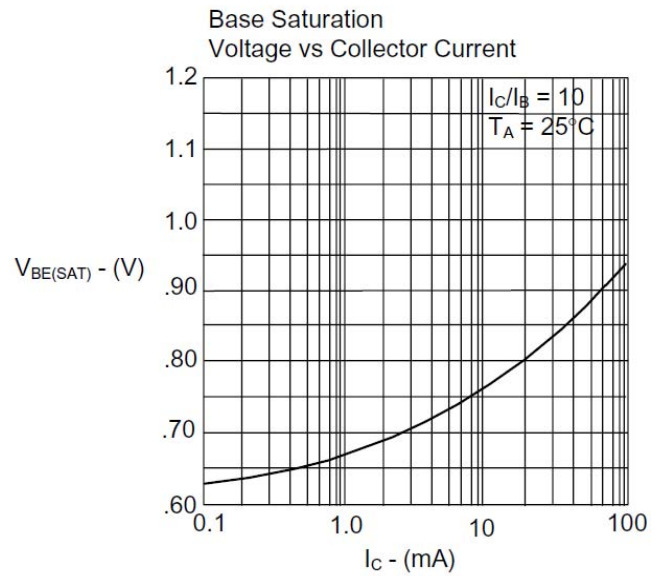
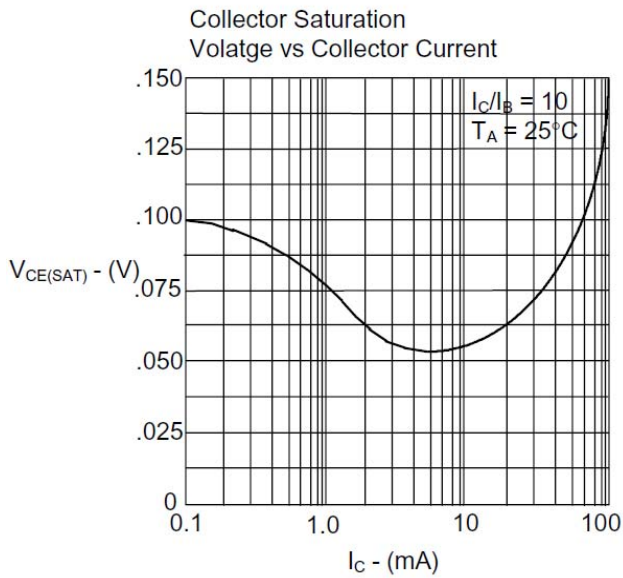
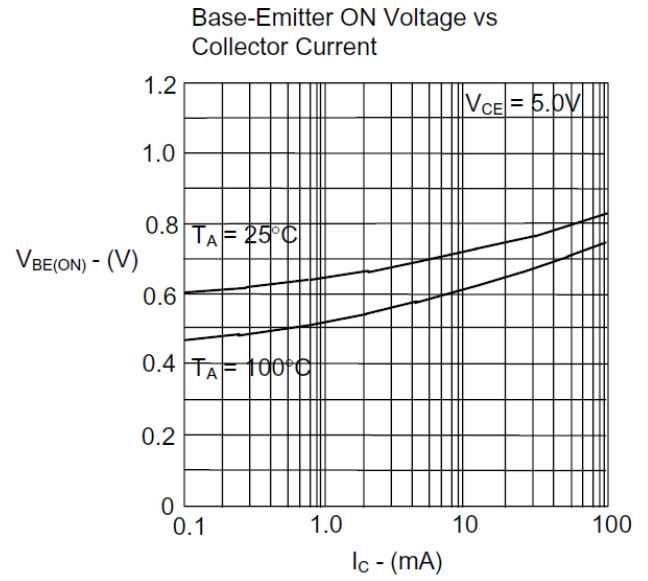
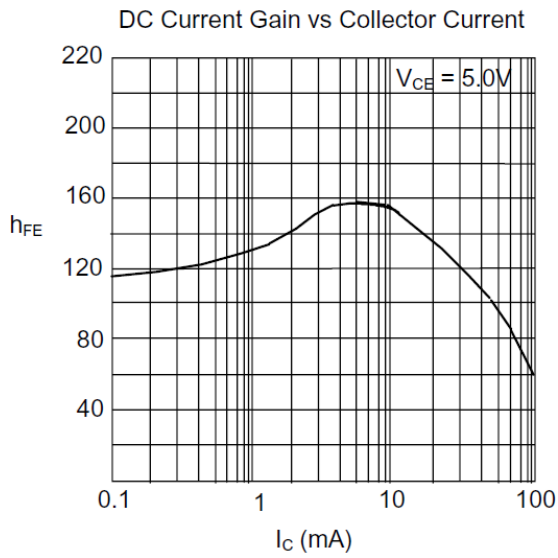

# MMBT3904

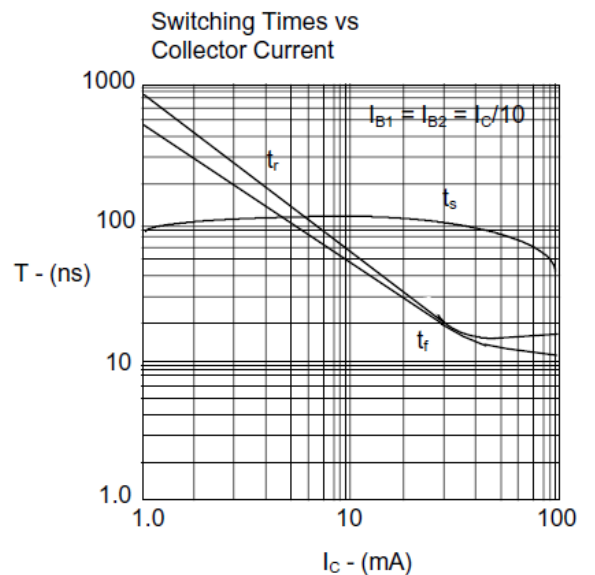
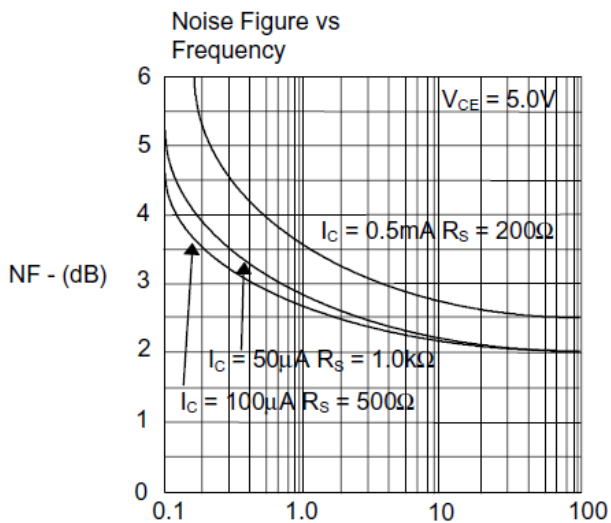
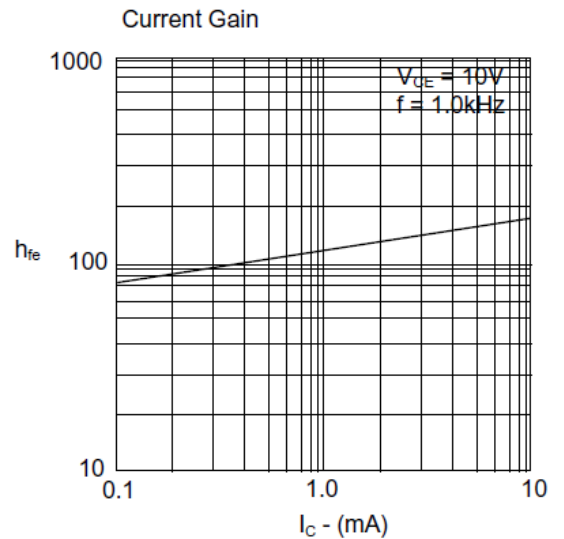
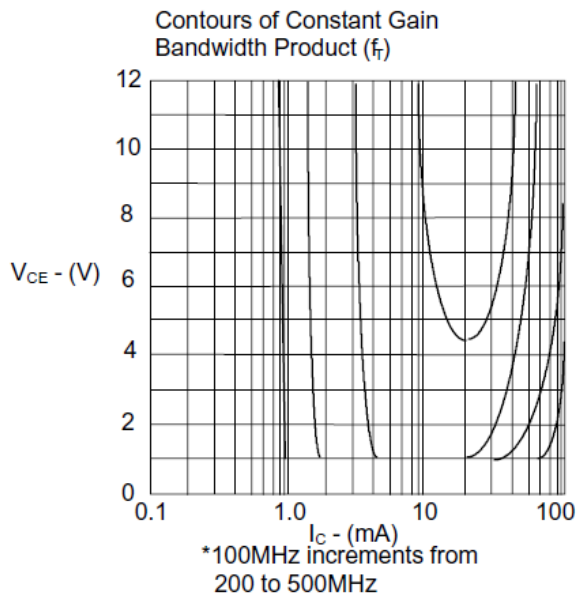
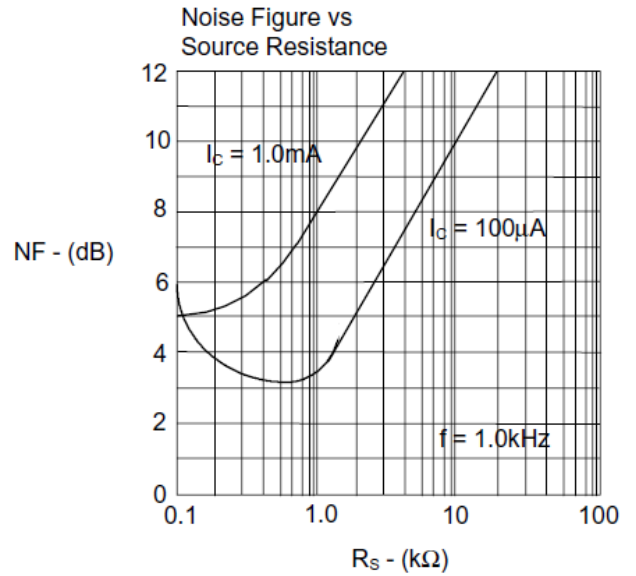
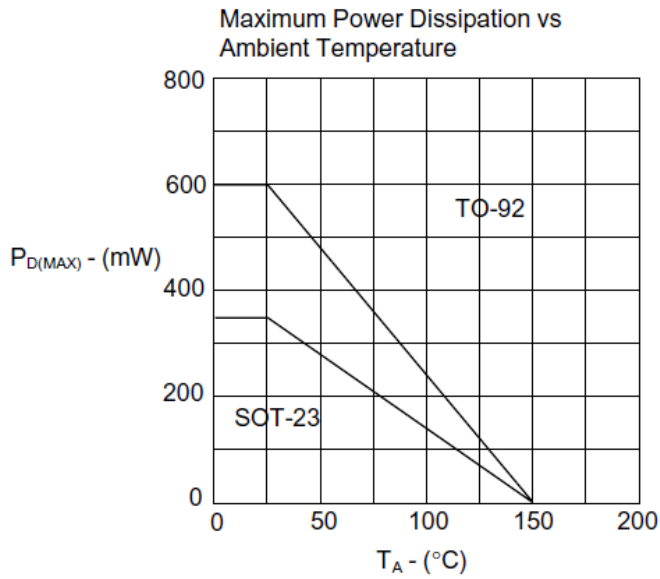

# MMBT3904

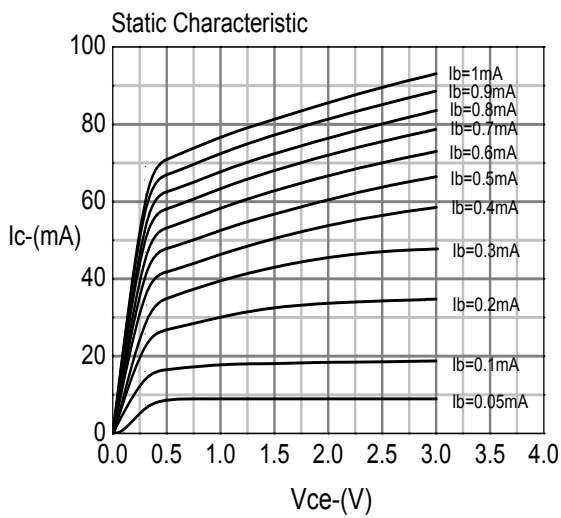
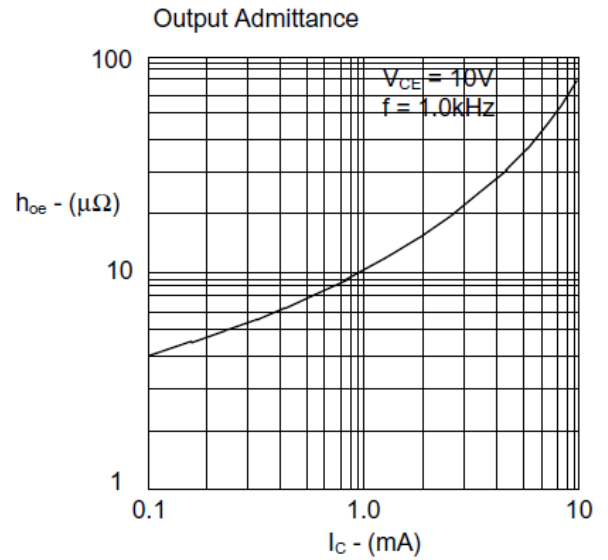
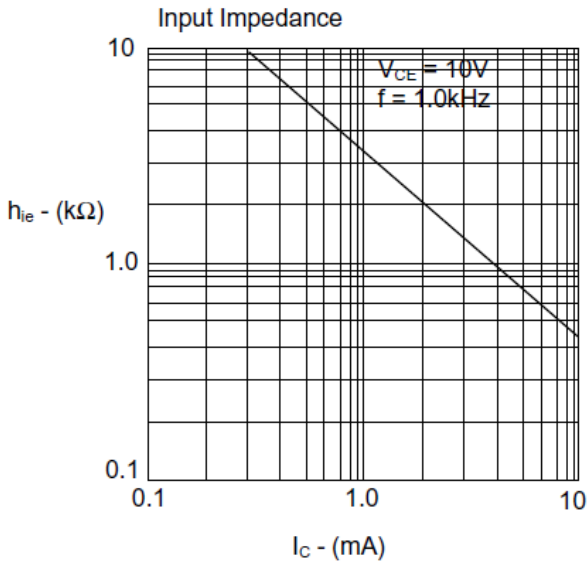
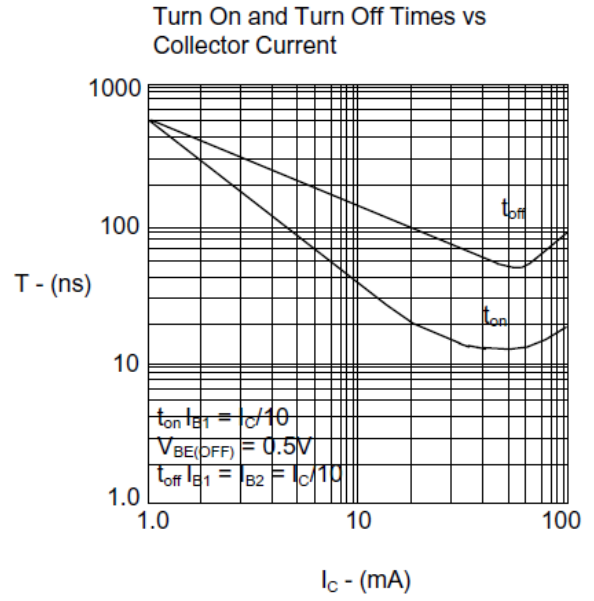
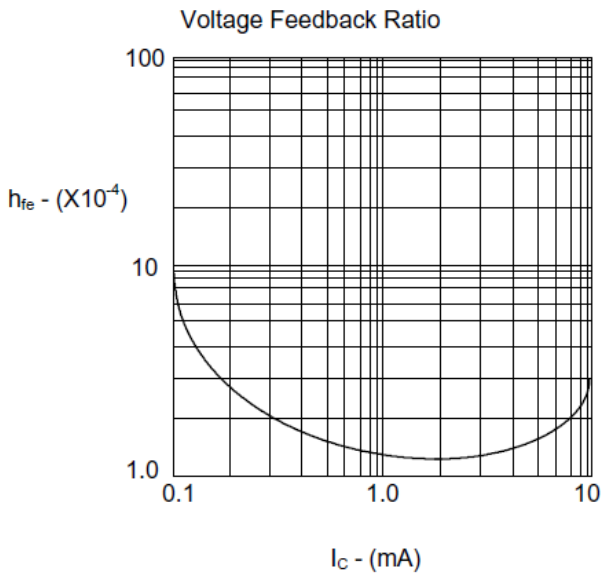

# MMBT3904

## ■SOT-23 Package Outline Dimensions

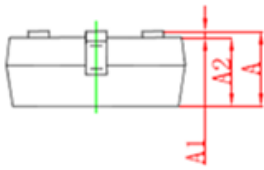
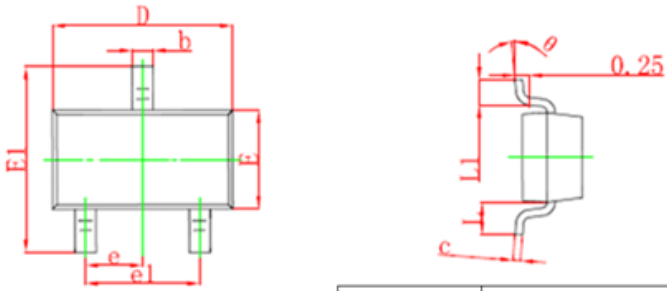

Symbol	Dimensions In Millimeters		Dimensions In Inches	
	Min	Max	Min	Max
A	0.900	1.150	0.035	0.045
A1	0.000	0.100	0.000	0.004
A2	0.900	1.050	0.035	0.041
b	0.300	0.500	0.012	0.020
c	0.100	0.200	0.004	0.008
D	2.800	3.000	0.110	0.118
E	1.200	1.400	0.047	0.055
E1	2.250	2.550	0.089	0.100
e	0.950TYP		0.037TYP	
e1	1.800	2.000	0.071	0.079
L	0.550REF		0.022REF	
L1	0.300	0.500	0.012	0.020
theta	0°	8°	0°	8°

## ■SOT-23 Suggested Pad Layout

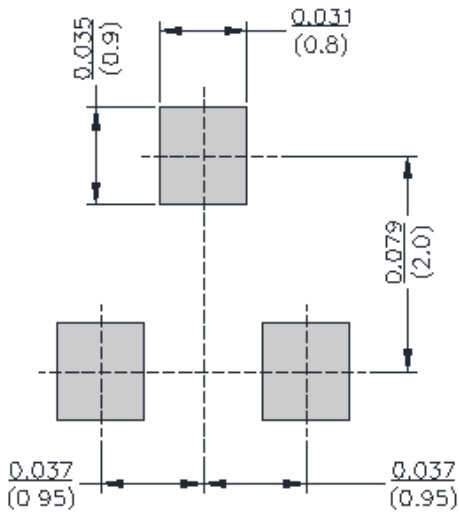

# MMBT3904

## ■ Marking Information

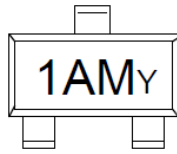

1AM = Product Type Marking Code  
Y = Date Code Marking

Date code Key (2 years a cycle)

Year	2011											
Month	Jan	Feb	Mar	Apr	May	Jun	Jul	Aug	Sep	Oct	Nov	Dec
Code	J	O	L	C	K	B	P	D	M	E	G	F

Year	2012											
Month	Jan	Feb	Mar	Apr	May	Jun	Jul	Aug	Sep	Oct	Nov	Dec
Code	W	N	Y	T	R	H	A	I	U	X	Z	S